

MANUAL TRANSMISSION

SECTION MT

CONTENTS





PREPARATION	MT- 2
ON-VEHICLE SERVICE	MT- 4
REMOVAL AND INSTALLATION	MT- 5
GEAR CONTROL	MT- 7
MAJOR OVERHAUL	MT- 9
DISASSEMBLY	MT-13
INSPECTION	MT-17
ASSEMBLY	MT-20
SERVICE DATA AND SPECIFICATIONS (S.D.S.)	MT-30

MT

PREPARATION

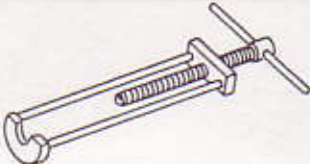
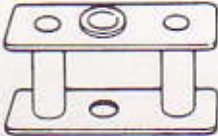

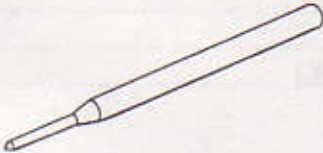

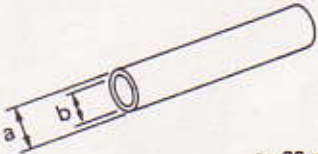
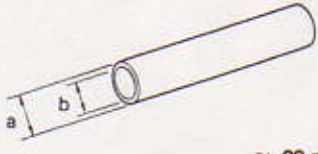
SPECIAL SERVICE TOOLS

*: Special tool or commercial equivalent

Tool number Tool name	Description
ST23810001 Adapter setting plate	 <p>Fixing adapter plate with gear assembly</p>
KV32101330 Puller	 <p>Removing overdrive mainshaft bearing</p>
KV31100401 Transmission press stand	 <p>Pressing counter gear and mainshaft</p>
ST22520000 Wrench	 <p>Tightening mainshaft lock nut</p>
ST23540000* Pin punch	 <p>Removing and installing fork rod retaining pin</p>
ST30031000* Puller	 <p>Removing 1st gear bushing Removing main drive gear bearing</p>
ST23860000* Drift	 <p>Installing counter drive gear</p> <p>a: 38 mm (1.50 in) dia. b: 33 mm (1.30 in) dia.</p>
ST22360002* Drift	 <p>Installing counter gear front and rear end bearings</p> <p>a: 29 mm (1.14 in) dia. b: 23 mm (0.91 in) dia.</p>

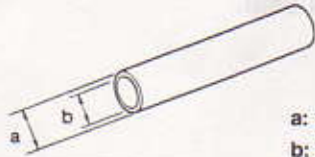
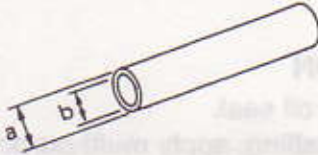
PREPARATION

*: Special tool or commercial equivalent

Tool number Tool name	Description	
ST22350000* Drift	 <p>a: 34 mm (1.34 in) dia. b: 28 mm (1.10 in) dia.</p>	Installing O.D. gear bushing
ST23800000* Drift	 <p>a: 44 mm (1.73 in) dia. b: 31 mm (1.22 in) dia.</p>	Installing front cover oil seal
ST33400001* Drift	 <p>a: 60 mm (2.36 in) dia. b: 47 mm (1.85 in) dia.</p>	Installing rear oil seal
ST30720000* Drift	 <p>a: 77 mm (3.03 in) dia. b: 55.5 mm (2.185 in) dia.</p>	Installing mainshaft ball bearing
ST30613000* Drift	 <p>a: 71.5 mm (2.815 in) dia. b: 47.5 mm (1.870 in) dia.</p>	Installing main drive gear bearing
ST33200000* Drift	 <p>a: 60 mm (2.36 in) dia. b: 44.5 mm (1.752 in) dia.</p>	Installing counter rear bearing Installing 3rd & 4th synchronizer assembly

COMMERCIAL SERVICE TOOLS

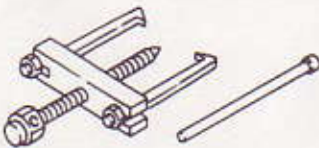
Tool name	Description	
Puller		Removing counter bearings, counter drive and O.D. gears

ON-VEHICLE SERVICE



Replacing Rear Oil Seal

REMOVAL

1. Pull out propeller shaft. — Refer to section PD.
2. Remove oil seal.

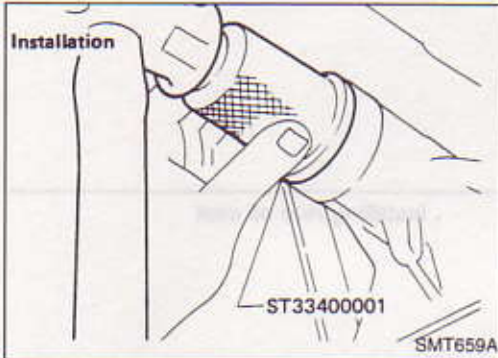

INSTALLATION

1. Install rear oil seal.
 - Before installing, apply multi-purpose grease to seal lip.
2. Install propeller shaft. — Refer to section PD.

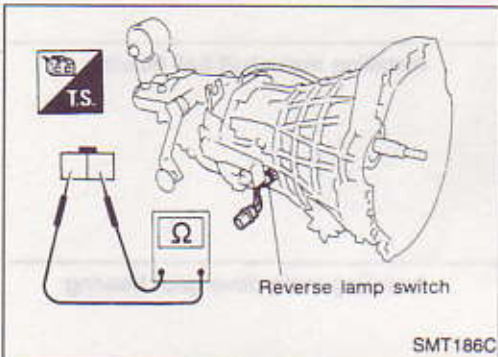

Position Switch Check

REVERSE LAMP SWITCH

- Check continuity.

Gear position	Continuity
Reverse	Yes
Except reverse	No

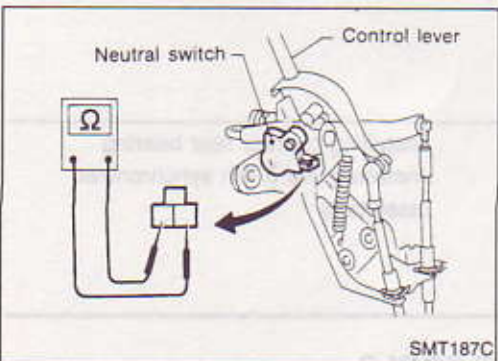

NEUTRAL SWITCH

- Check continuity.

Gear position	Continuity
Neutral	Yes
Except neutral	No

REMOVAL AND INSTALLATION

Removal

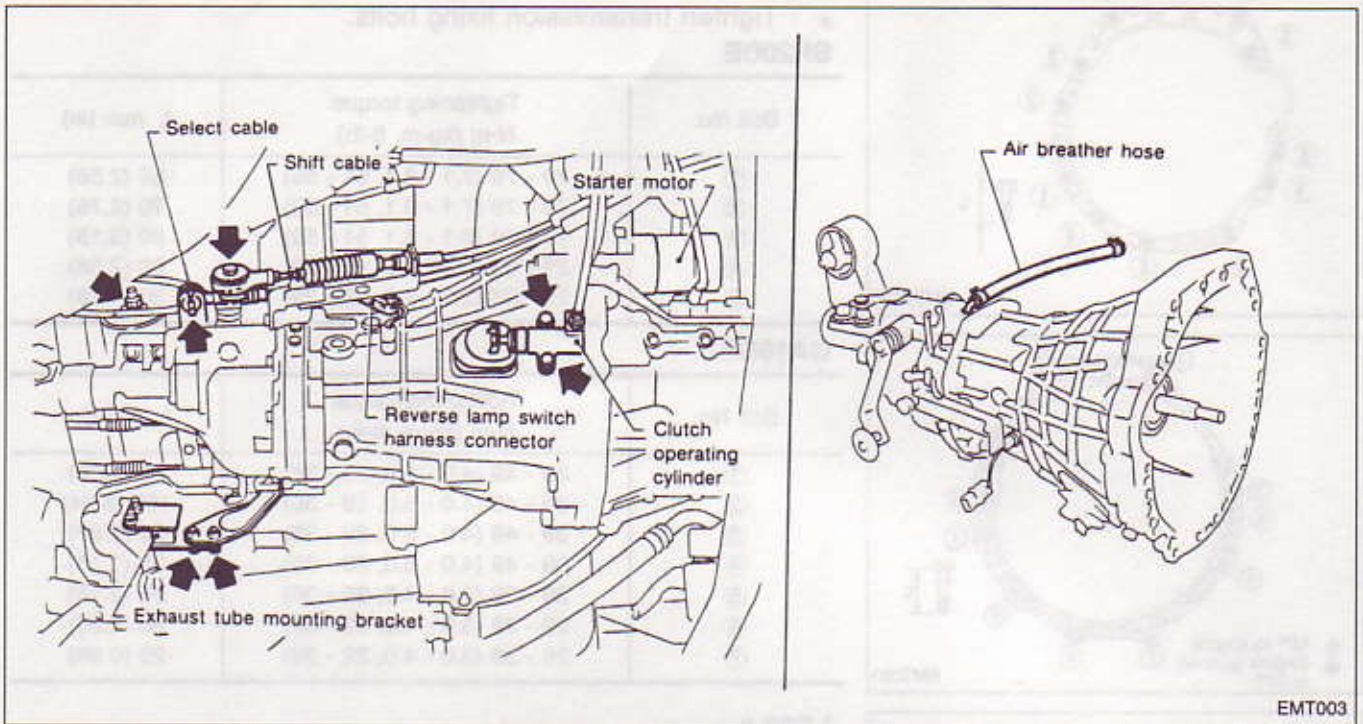

- Remove clutch operating cylinder from transmission.
- Disconnect reverse lamp switch harness connector.
- Disconnect speedometer cable.
- Remove starter motor from transmission.
- Remove propeller shaft. — Refer to section PD.

Insert plug into rear oil seal after removing propeller shaft.

Be careful not to damage spline, sleeve yoke and rear oil seal when removing propeller shaft.

- Separate exhaust tube mounting bracket from transmission.
- Remove select cable and shift cable from transmission.
- Support manual transmission with a jack.
- Remove rear mounting bracket.
- Remove air breather hose.
- Remove transmission from engine.
- **Support manual transmission with jack while removing it.**

REMOVAL AND INSTALLATION

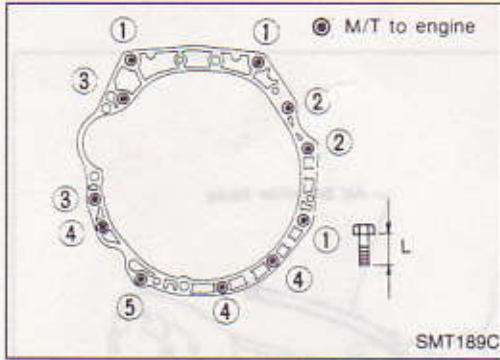

Installation

- Tighten transmission fixing bolts.

SR20DE

Bolt No.	Tightening torque N·m (kg·m, ft·lb)	L mm (in)
①	70 - 79 (7.1 - 8.1, 51 - 59)	65 (2.56)
②	70 - 79 (7.1 - 8.1, 51 - 59)	70 (2.76)
③	70 - 79 (7.1 - 8.1, 51 - 59)	80 (3.15)
④	29 - 39 (3.0 - 4.0, 22 - 29)	60 (2.36)
⑤	29 - 39 (3.0 - 4.0, 22 - 29)	30 (1.18)

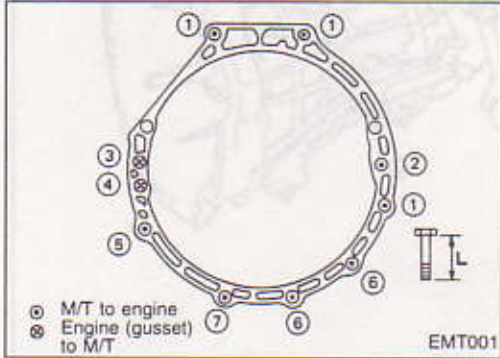

GA16DE

Bolt No.	Tightening torque N·m (kg·m, ft·lb)	L mm (in)
①	39 - 49 (4.0 - 5.0, 29 - 36)	60 (2.36)
②	39 - 49 (4.0 - 5.0, 29 - 36)	100 (3.94)
③	39 - 49 (4.0 - 5.0, 29 - 36)	50 (1.97)
④	39 - 49 (4.0 - 5.0, 29 - 36)	35 (1.38)
⑤	29 - 39 (3.0 - 4.0, 22 - 36)	55 (2.16)
⑥	29 - 39 (3.0 - 4.0, 22 - 36)	60 (2.36)
⑦	29 - 39 (3.0 - 4.0, 22 - 36)	25 (0.98)

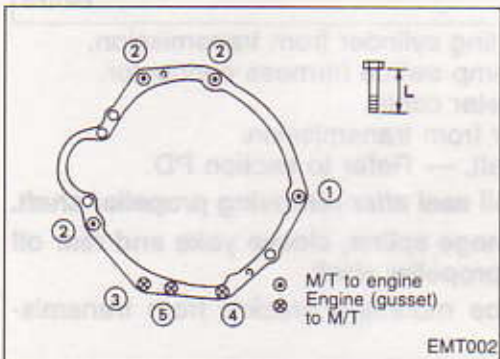

LD20-II

Bolt No.	Tightening torque N·m (kg·m, ft·lb)	L mm (in)
1	39 - 49 (4.0 - 5.0, 29 - 36)	65 (2.56)
2	39 - 49 (4.0 - 5.0, 29 - 36)	60 (2.36)
3	39 - 49 (4.0 - 5.0, 29 - 36)	65 (2.56)
4*	25 - 34 (2.5 - 3.5, 18 - 25)	55 (2.17)
5*	29 - 39 (3.0 - 4.0, 22 - 29)	50 (1.97)

*: With nut

- Install all parts removed. (Installation is in the reverse order of removal.)

GEAR CONTROL

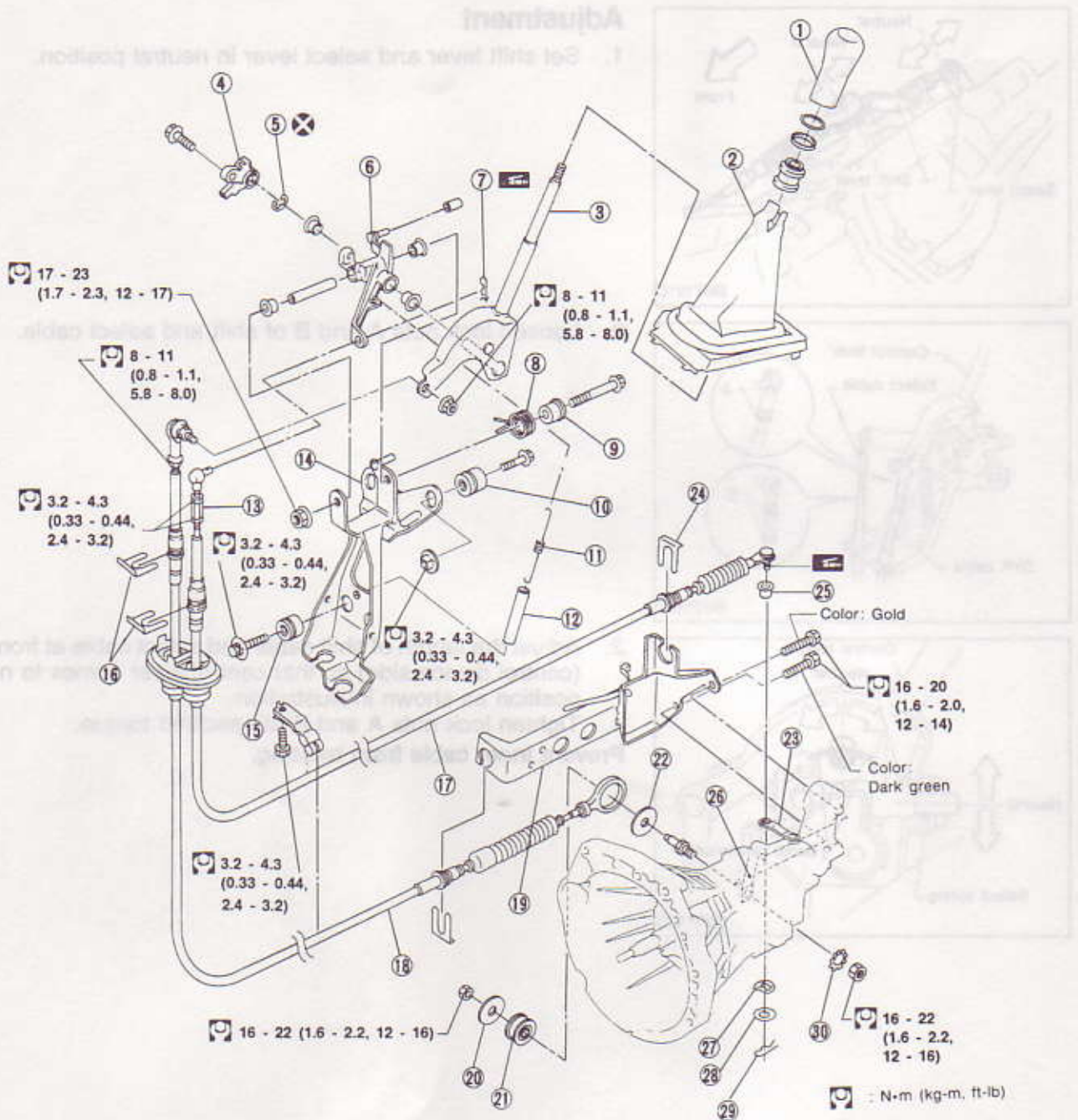

SMT190C

- ① Knob
- ② Console boot
- ③ Control lever
- ④ Neutral switch
- ⑤ E-ring
- ⑥ Select lever
- ⑦ Snap pin
- ⑧ Select spring
- ⑨ Spring guide
- ⑩ Floating rubber

- ⑪ Return spring
- ⑫ Tube
- ⑬ Adjuster
- ⑭ Base bracket
- ⑮ Floating rubber
- ⑯ Lock plate
- ⑰ Select cable assembly
- ⑱ Shift cable assembly
- ⑲ Cable mounting bracket
- ⑳ Washer

- ㉑ Insulator
- ㉒ Washer
- ㉓ Select lever
- ㉔ Lock plate
- ㉕ Insulator
- ㉖ Shift lever
- ㉗ Spring washer
- ㉘ Washer
- ㉙ Snap pin
- ㉚ Lock washer

MT-7

GEAR CONTROL

Adjustment

1. Set shift lever and select lever in neutral position.

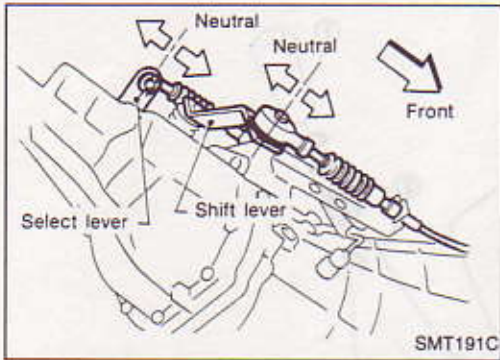

2. Loosen lock nuts A and B of shift and select cable.

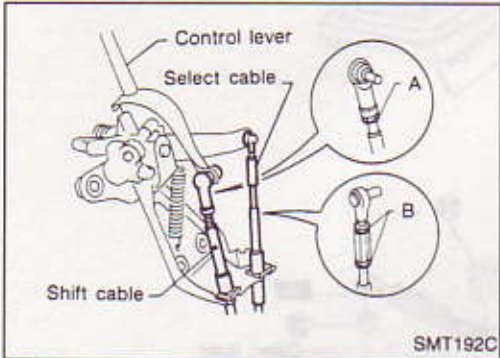

3. Adjust the length of shift cable and select cable at front side (control device side) so that control lever comes to neutral position as shown in illustration.

4. Tighten lock nuts A and B at specified torque.

Prevent inner cable from twisting.

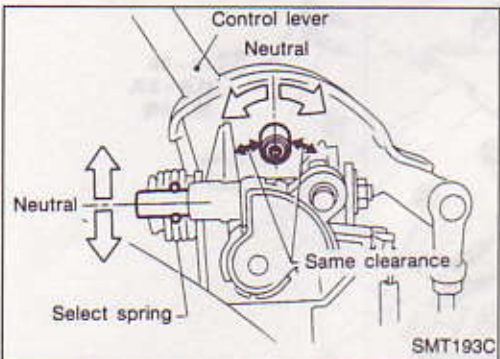

MAJOR OVERHAUL

Gear Components

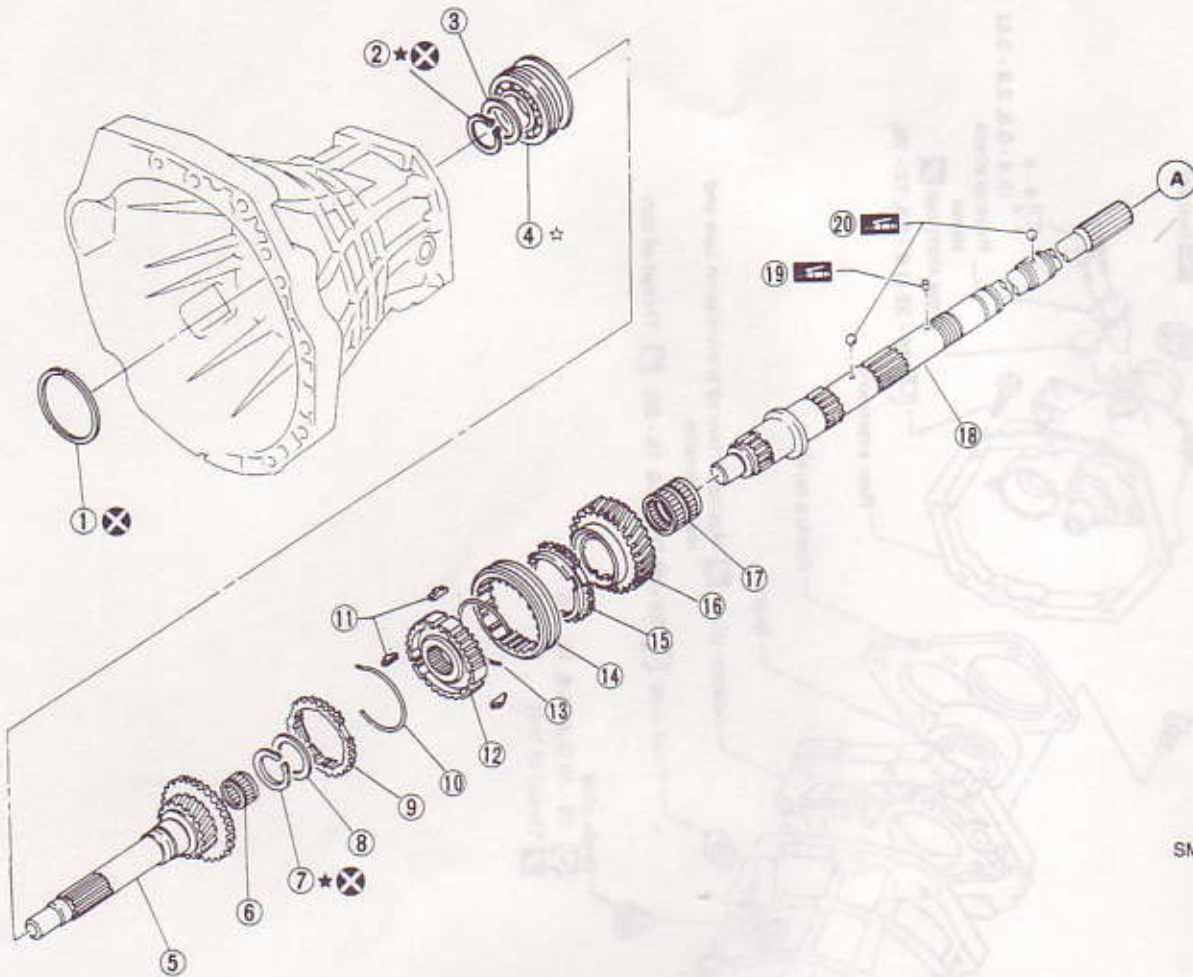

SMT198C-1

- | | | |
|-------------------------------------|--|----------------------------------|
| ① Main drive gear bearing snap ring | ②7 Insert spring | ⑤2 Mainshaft rear end bearing |
| ② Snap ring | ②8 Coupling sleeve | ⑤3 Snap ring |
| ③ Washer | ②9 Baulk ring | ⑤4 Counter rear bearing |
| ④ Main drive gear ball bearing | ③0 Needle bearing | ⑤5 Reverse counter gear spacer |
| ⑤ Main drive gear | ③1 1st gear bushing | ⑤6 Reverse counter gear |
| ⑥ Pilot bearing | ③2 1st main gear | ⑤7 Overdrive counter gear |
| ⑦ Snap ring | ③3 Thrust washer | ⑤8 Countershaft rear end bearing |
| ⑧ Washer | ③4 Mainshaft ball bearing | ⑤9 Countershaft lock nut |
| ⑨ Baulk ring | ③5 Bush | ⑥0 Shim |
| ⑩ Spread spring | ③6 Reverse main gear | ⑥1 Counter shaft front bearing |
| ⑪ Shifting insert | ③7 Needle bearing | ⑥2 Snap ring |
| ⑫ 3rd & 4th synchronizer hub | ③8 Baulk ring | ⑥3 Sub-gear bracket |
| ⑬ Spread spring | ③9 Spread spring | ⑥4 Sub-gear spring |
| ⑭ Coupling sleeve | ④0 O.D. (5th) & reverse synchronizer hub | ⑥5 Sub-gear |
| ⑮ Baulk ring | ④1 Shifting insert | ⑥6 Counter drive gear |
| ⑯ 3rd main gear | ④2 Spread spring | ⑥7 Woodruff key |
| ⑰ Needle bearing | ④3 Coupling sleeve | ⑥8 Counter gear |
| ⑱ Main shaft | ④4 Baulk ring | ⑥9 Reverse idler shaft |
| ⑲ Steel roller | ④5 O.D. (5th) main gear | ⑦0 Snap ring |
| ⑳ Steel ball | ④6 Needle bearing | ⑦1 Reverse idler thrust washer |
| ㉑ Needle bearing | ④7 Overdrive gear bushing | ⑦2 Reverse idler gear |
| ㉒ 2nd main gear | ④8 Thrust washer | ⑦3 Reverse idler gear bearing |
| ㉓ 2nd inner baulk ring | ④9 Speedometer drive gear | ⑦4 Reverse idler thrust washer |
| ㉔ Synchronizer cone | ⑤0 Mainshaft lock nut | ⑦5 Snap ring |
| ㉕ 2nd outer baulk ring | ⑤1 Snap ring | |
| ㉖ 1st & 2nd synchronizer hub | | |

MAJOR OVERHAUL

Gear Components (Cont'd)

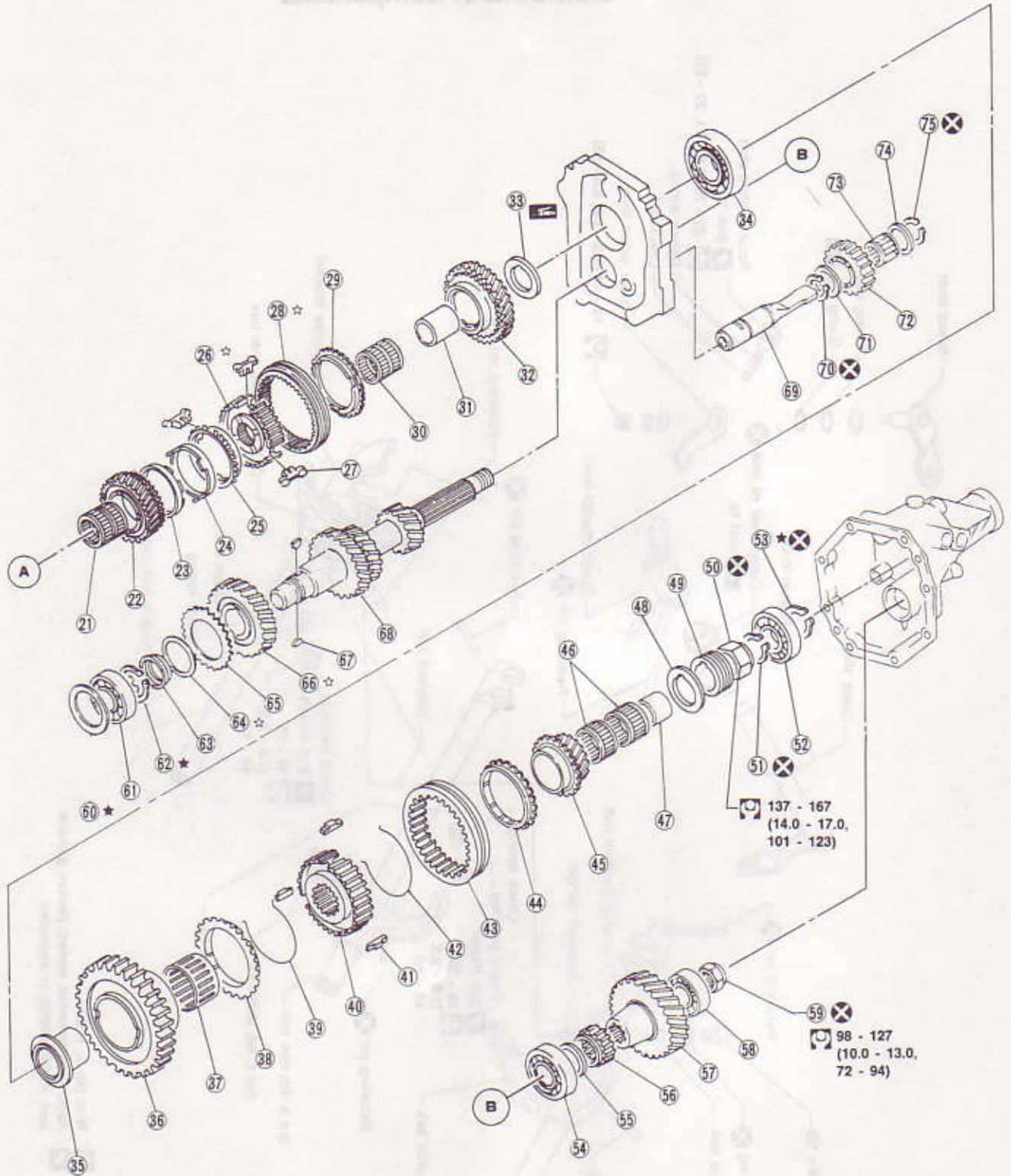

Apply gear oil to gears, shafts, synchronizers, and bearings when assembling.

- ☆ : Select proper thickness.
- ☆ : Pay attention to its direction.
- ⊗ N·m (kg-m, ft-lb)

DISASSEMBLY

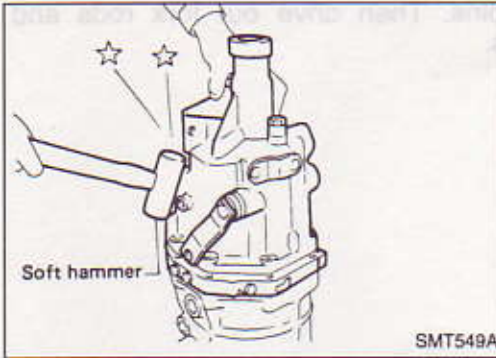

Case Components

Before disassembling transmission, drain transmission oil.

1. Remove rear extension by lightly tapping it.

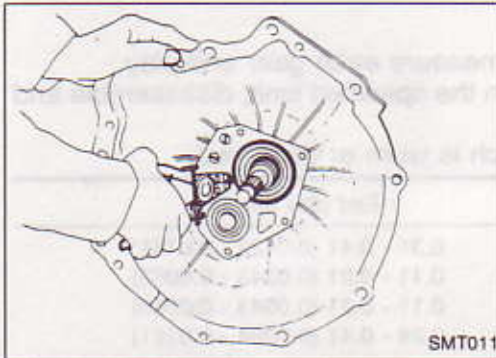

2. Remove front cover, gasket, shim of countershaft front bearing, and snap ring of main drive gear ball bearing.

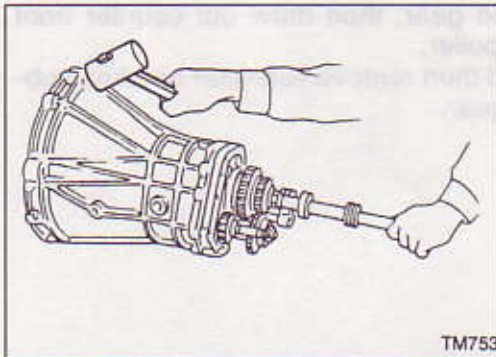

3. Separate transmission case from adapter plate.

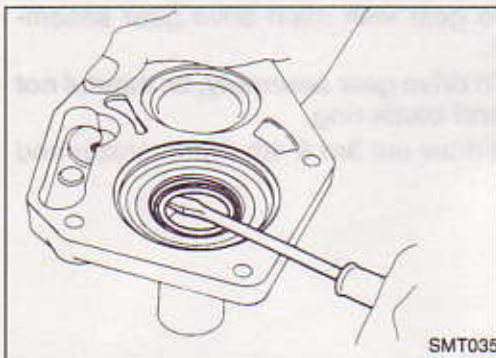

4. Remove front cover oil seal.
Be careful not to damage front cover mating surface.

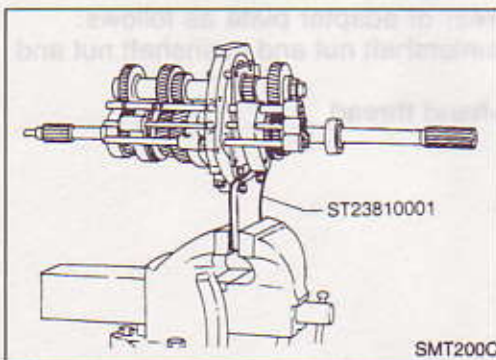

Shift Control Components

1. Set up Tool on adapter plate.
2. Remove check ball plugs, check springs, and check balls.

DISASSEMBLY

Shift Control Components (Cont'd)

3. Drive out retaining pins. Then drive out fork rods and remove interlock balls.

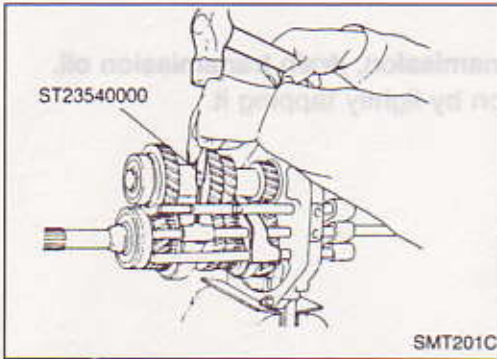

Gear Components

1. Before disassembly, measure each gear end play.
 - If end play is not within the specified limit, disassemble and check parts.
 - Replace any part which is worn or damaged.

Gear	End play mm (in)
1st	0.31 - 0.41 (0.0122 - 0.0161)
2nd	0.11 - 0.21 (0.0043 - 0.0083)
3rd	0.11 - 0.21 (0.0043 - 0.0083)
O.D.	0.24 - 0.41 (0.0094 - 0.0161)

2. Mesh 2nd and reverse gear, then draw out counter front bearing with suitable puller.
3. Remove snap ring and then remove sub-gear bracket, sub-gear spring and sub-gear.

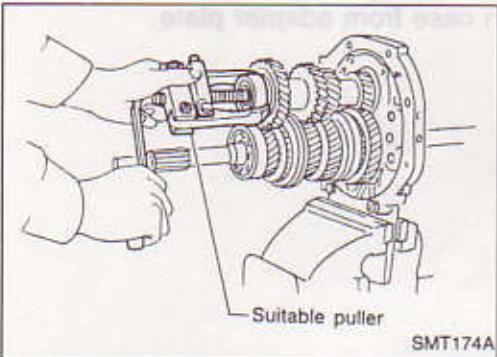
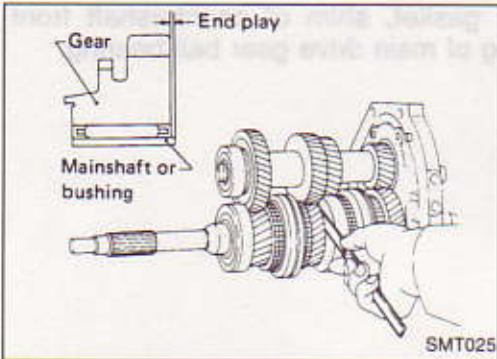

4. Draw out counter drive gear with main drive gear assembly with suitable puller.
 - **When drawing out main drive gear assembly, be careful not to drop pilot bearing and baulk ring.**
5. Remove snap ring and draw out 3rd & 4th synchronizer and 3rd gear.

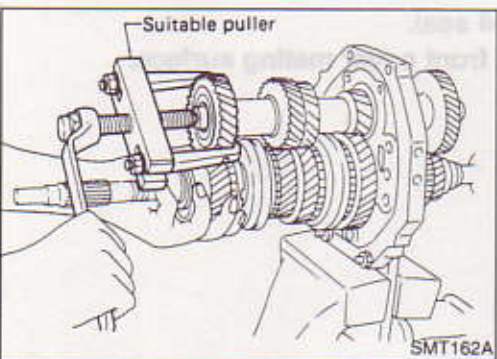

6. Disassemble parts at rear of adapter plate as follows:
 - a. Release staking on countershaft nut and mainshaft nut and loosen these nuts.

Mainshaft nut: Left-hand thread

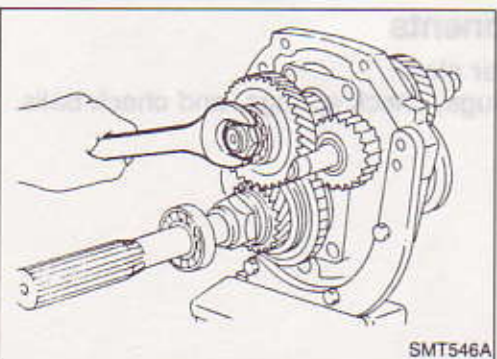

DISASSEMBLY

Gear Components (Cont'd)

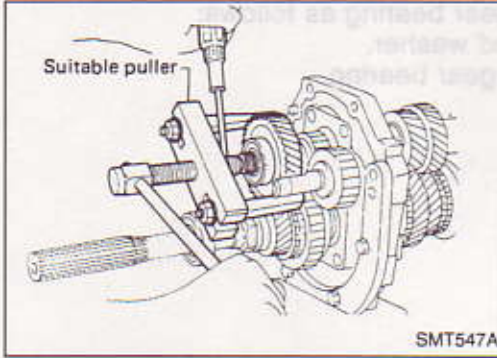

- b. Pull out O.D. counter gear and bearing with suitable puller.
- c. Draw out reverse counter gear and spacer.
- d. Remove snap rings from reverse idler shaft, and draw out reverse idler gear, thrust washers and reverse idler gear bearing.

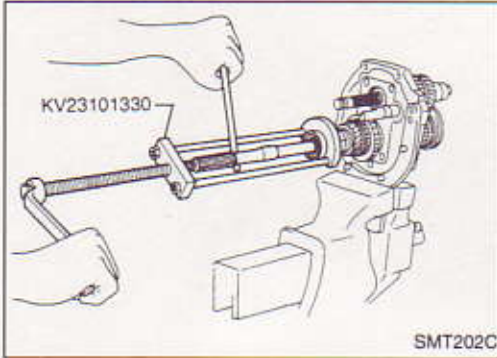

- e. Remove snap ring and pull out mainshaft rear end bearing, then remove snap ring.
- f. Remove mainshaft nut.
- g. Remove speedometer drive gear and steel ball.
- h. Remove thrust washer.
- i. Remove O.D. main gear, needle bearing and baulk ring (O.D.).
- j. Remove coupling sleeve (O.D. & reverse), shift inserts and shifting insert springs.
- k. Remove counter gear by tapping rear end of counter gear.
- l. Press out O.D. gear bushing, O.D. & reverse synchronizer hub, baulk ring (reverse), reverse main gear, needle bearing and bush together.

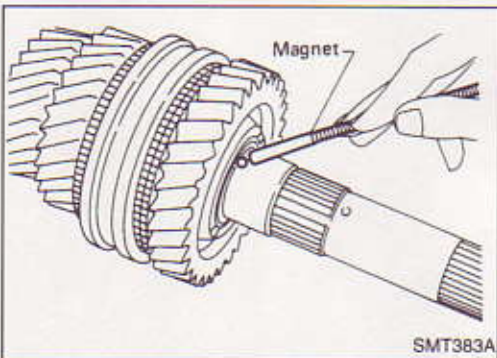
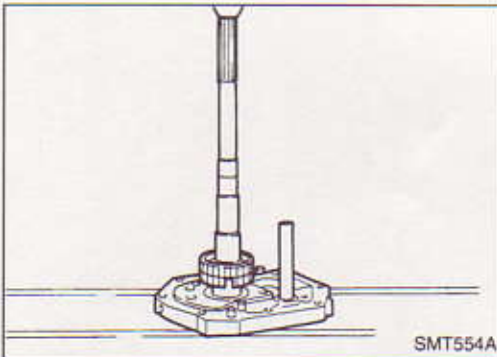

- 7. Remove thrust washer, steel ball, 1st main gear and needle bearing.

Be careful not to lose steel ball.

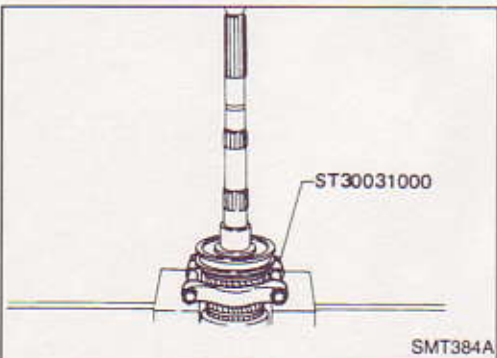

- 8. Press out 1st gear mainshaft bushing together with 2nd main gear with Tool. Then remove 2nd gear needle bearing.

DISASSEMBLY

Gear Components (Cont'd)

9. Remove main drive gear bearing as follows:
 - a. Remove snap ring and washer.
 - b. Press out main drive gear bearing.

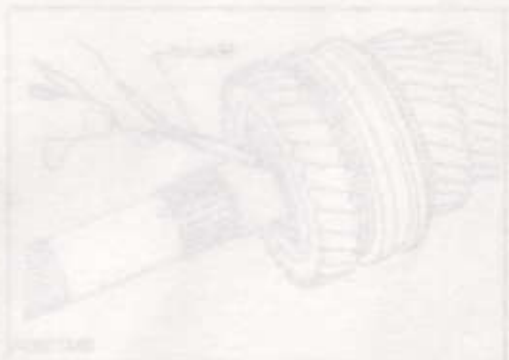
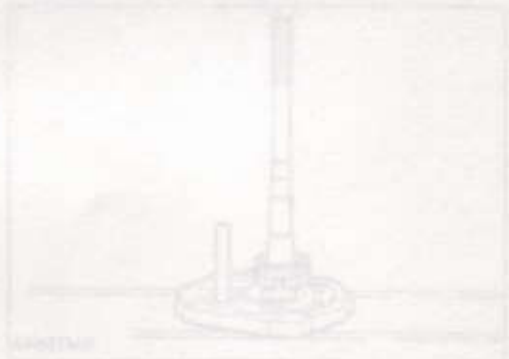
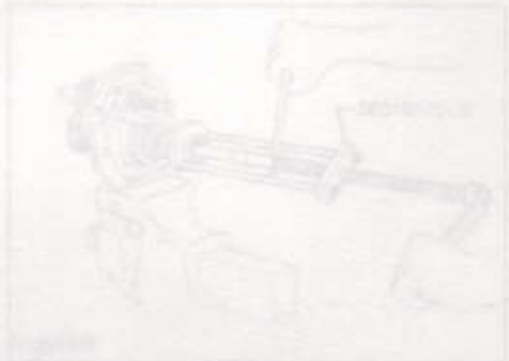
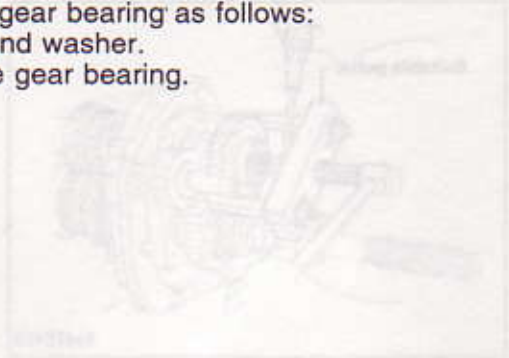
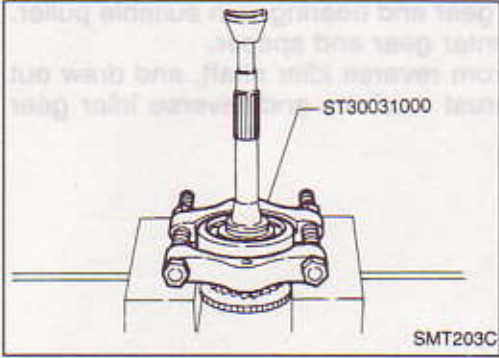

INSPECTION

Shift Control Components

- Check contact surface and sliding surface of fork rods for wear, scratches, projections or other damage.

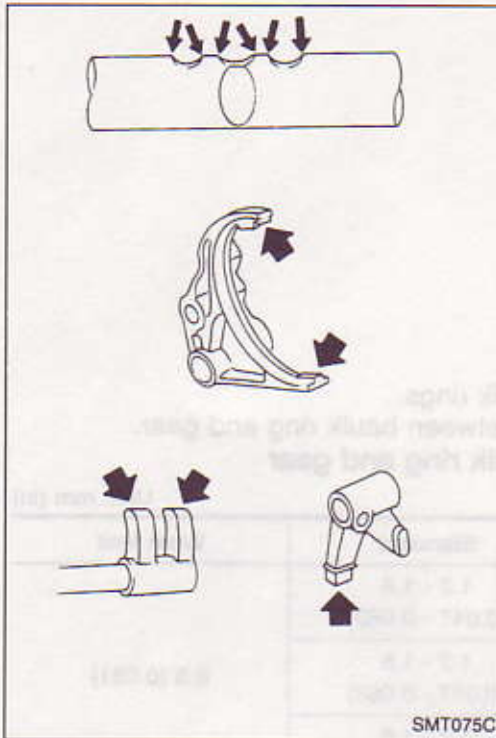

SMT075C

Gear Components

GEARS AND SHAFTS

- Check shafts for cracks, wear or bending.
- Check gears for excessive wear, chips or cracks.

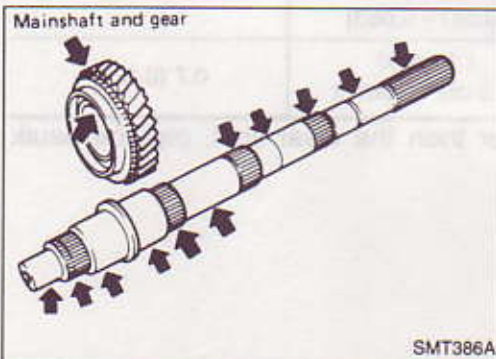

SMT386A

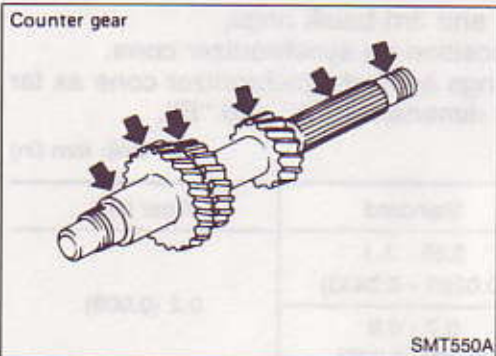

SMT550A

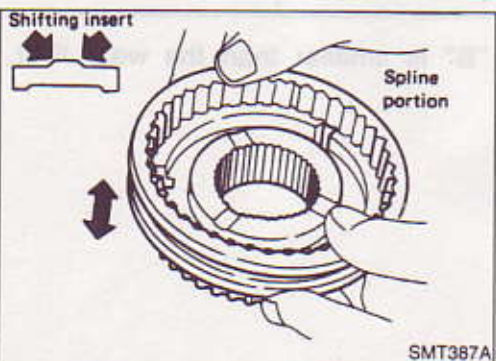

SMT387A

SYNCHRONIZERS

- Check spline portion of coupling sleeves, hubs and gears for wear or cracks.
- Check baulk rings for cracks or deformation.
- Check shifting inserts for wear or deformation.
- Check insert springs for deformation.

INSPECTION

Gear Components (Cont'd)

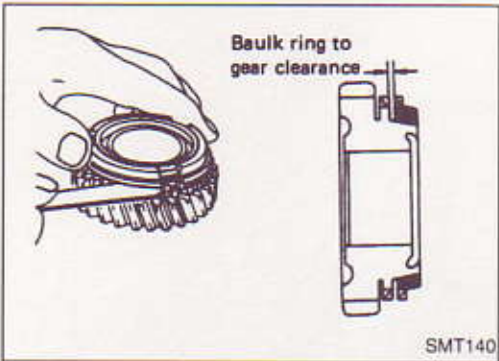
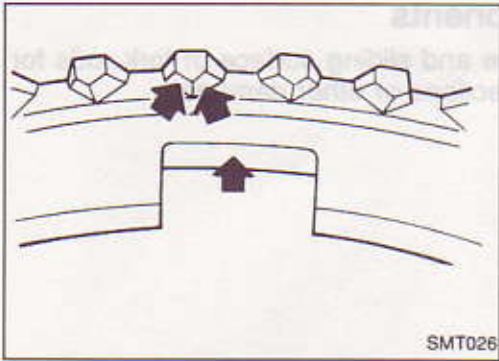

- Measure wear of baulk rings.
 - a. Measure clearance between baulk ring and gear.
- Clearance between baulk ring and gear**

Unit: mm (in)

Dimension	Standard	Wear limit
1st	1.2 - 1.6 (0.047 - 0.063)	0.8 (0.031)
3rd and main drive	1.2 - 1.6 (0.047 - 0.063)	
O.D.	1.2 - 1.6 (0.047 - 0.063)	
Reverse	1.1 - 1.55 (0.0433 - 0.0610)	0.7 (0.028)

If the clearance is smaller than the wear limit, replace baulk ring.

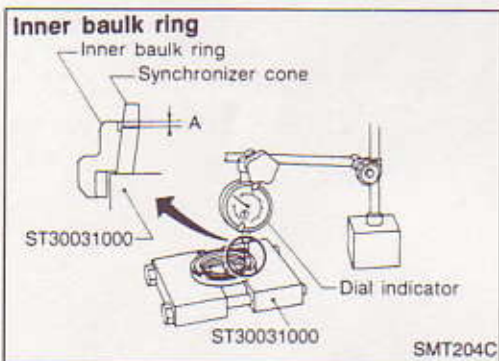

- Measure wear of 2nd and 3rd baulk rings.
- a. Place baulk rings in position on synchronizer cone.
- b. While holding baulk rings against synchronizer cone as far as it will go, measure dimensions "A" and "B".

Unit: mm (in)

Dimension	Standard	Wear limit
A	0.65 - 1.1 (0.0256 - 0.0433)	0.2 (0.008)
B	0.7 - 0.9 (0.028 - 0.035)	

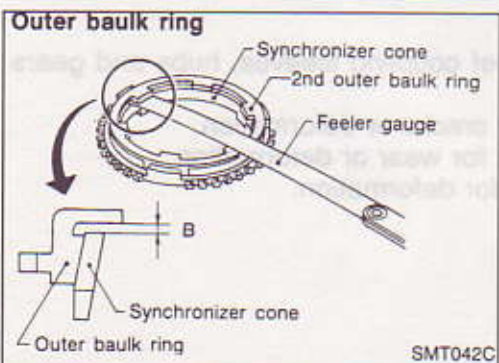

- c. If dimension "A" or "B" is smaller than the wear limit, replace baulk ring.

INSPECTION

Gear Components (Cont'd)

BEARINGS

- Make sure bearings roll freely and are free from noise, crack, pitting or wear.

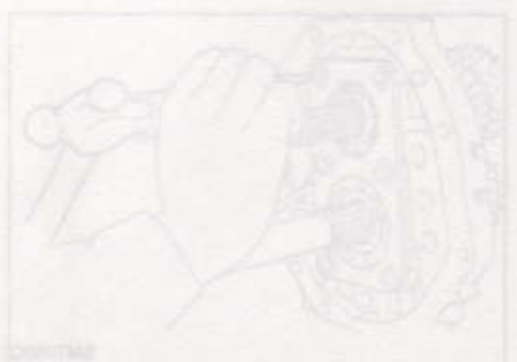
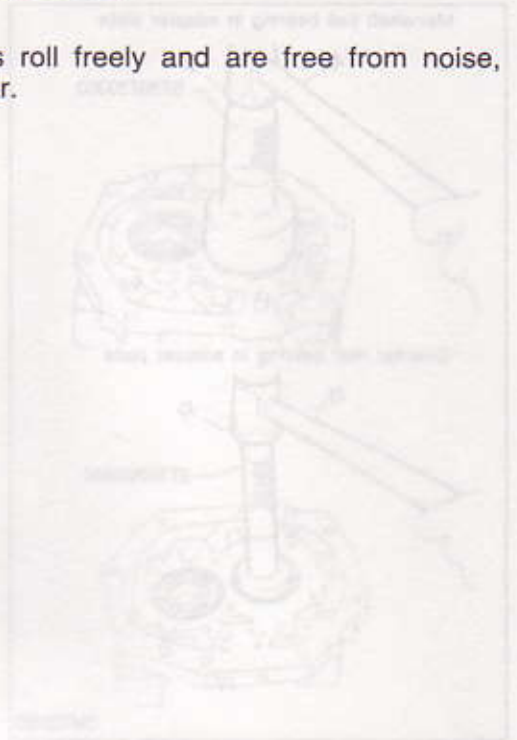
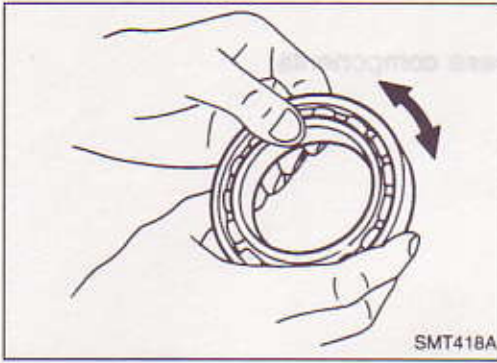

ASSEMBLY

Gear Components

1. Install bearings into case components.

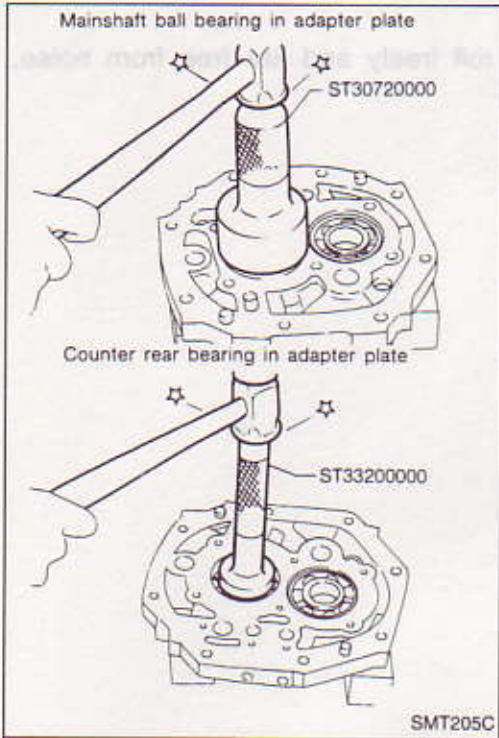

2. Assemble adapter plate parts.

- Install oil gutter on adapter plate and expand on rear side.

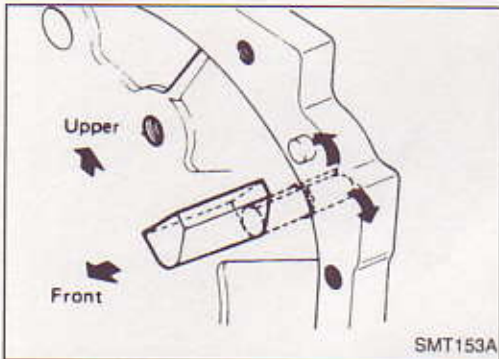

- Install bearing retainer.

- a. Insert reverse shaft, then install bearing retainer.

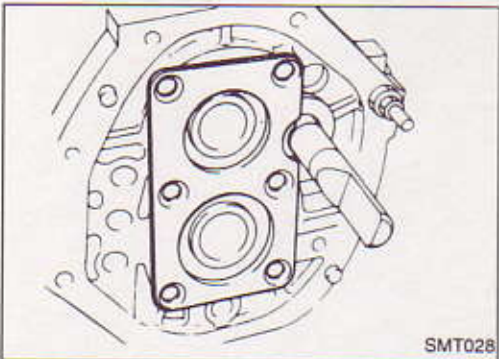

- b. Tighten each screw from 16 to 22 N·m (1.6 to 2.3 kg·m, 12 to 16 ft·lb), then stake each at two points.

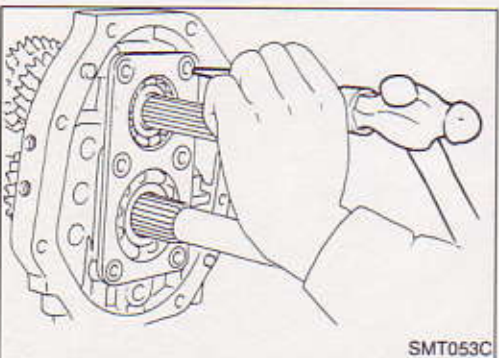

ASSEMBLY

Gear Components (Cont'd)

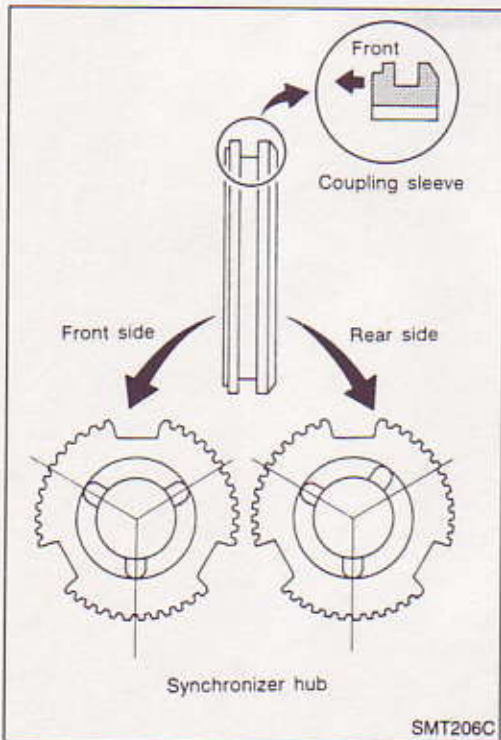
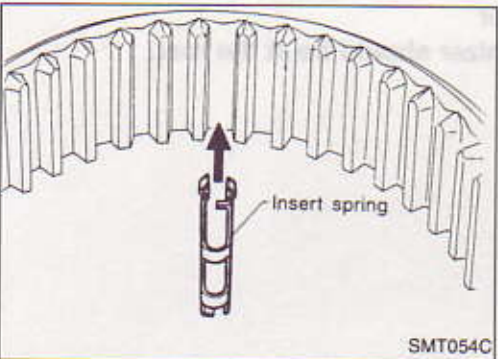
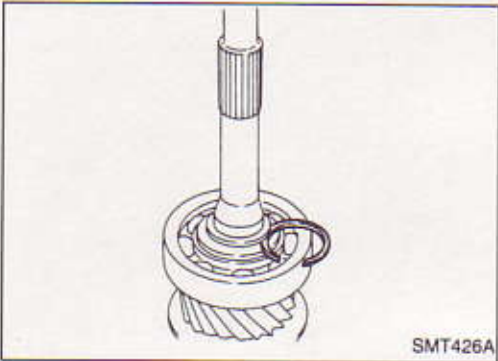
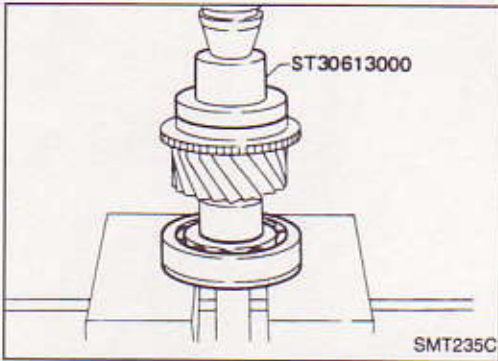

3. Install main drive gear bearing.
 - a. Press main drive gear bearing.
 - b. Install main drive gear spacer.

- c. Select proper main drive gear snap ring to minimize clearance of groove and install it.

Allowable clearance of groove:
0 - 0.13 mm (0 - 0.0051 in)
Main drive gear snap ring:
Refer to S.D.S.

4. Assemble synchronizers.
 - 1st & 2nd synchronizer

- Check coupling sleeve and synchronizer hub orientation.

ASSEMBLY

Gear Components (Cont'd)

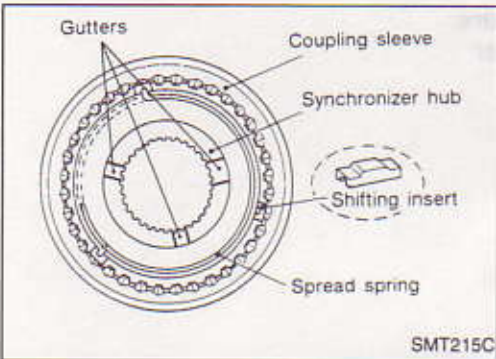
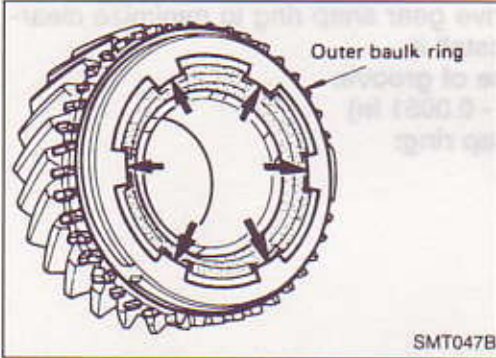
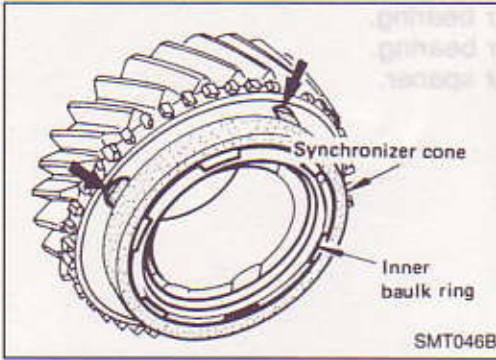

- 3rd & 4th synchronizer
The 3 gutters of synchronizer should be at the rear.

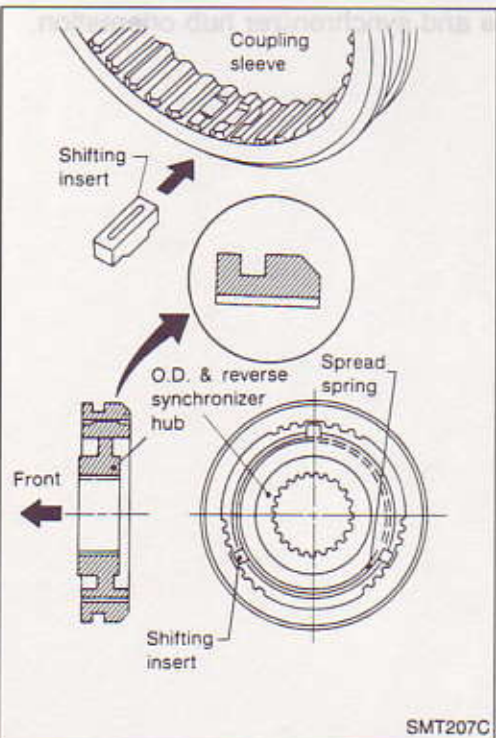

- O.D. & reverse synchronizer

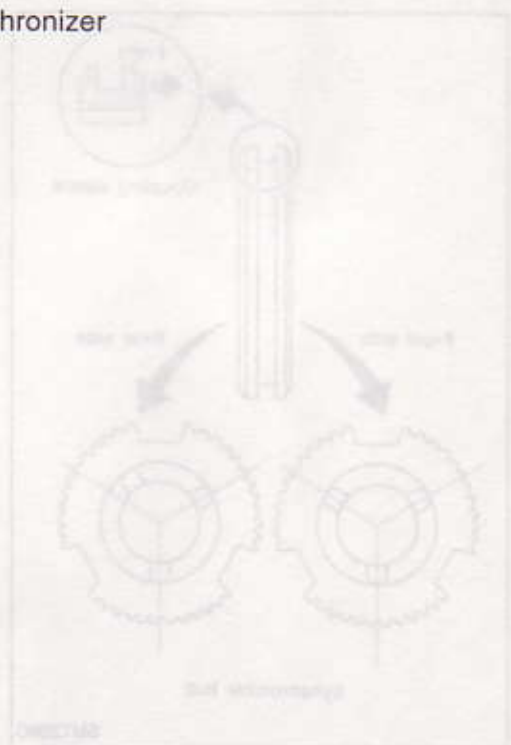
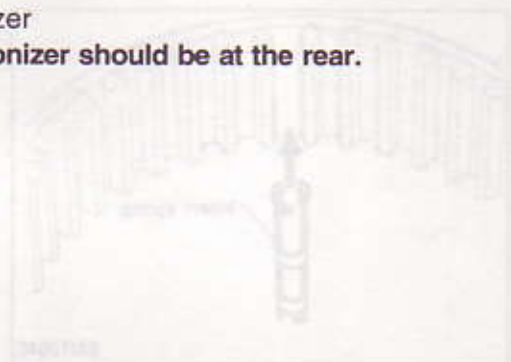
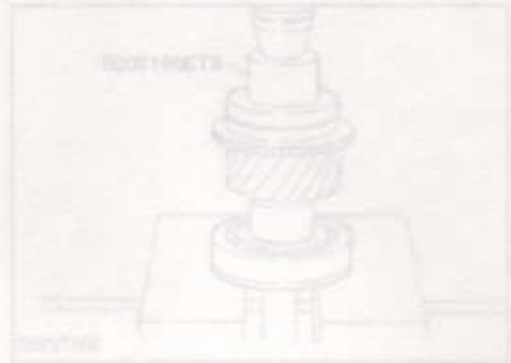

ASSEMBLY

Gear Components (Cont'd)

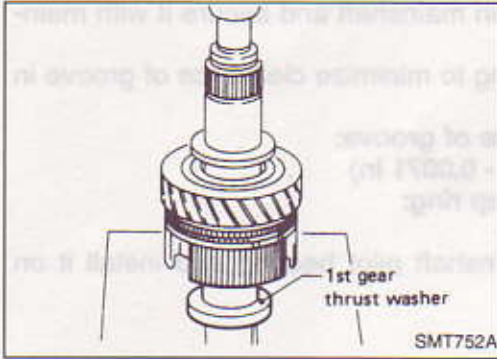

5. Install front side components on mainshaft.
 - a. Assemble 2nd main gear, needle bearing and 1st & 2nd synchronizer assembly, then press 1st gear bushing on mainshaft.
 - b. Install 1st main gear.

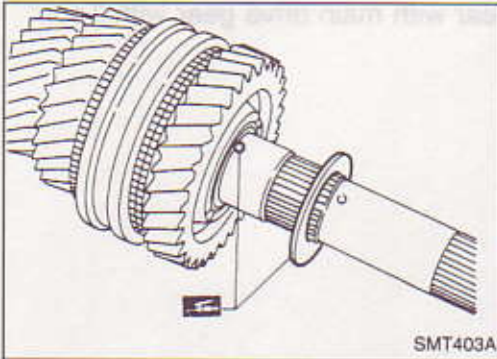

- c. Install steel ball and 1st gear washer.
- Apply multi-purpose grease to steel ball and 1st gear washer before installing.**

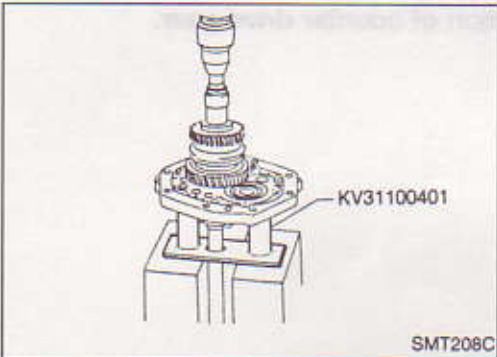

6. Install mainshaft and counter gear on adapter plate and main drive gear on mainshaft as follows:
 - a. Press mainshaft assembly to adapter plate with Tool.

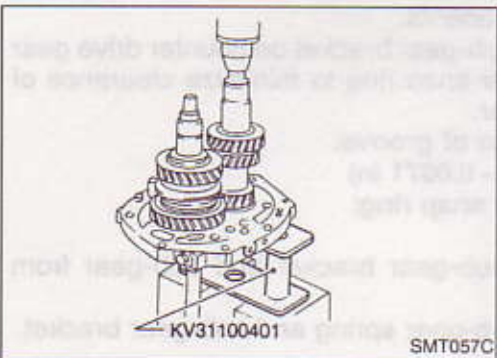

- b. Press counter gear into adapter plate with Tool.

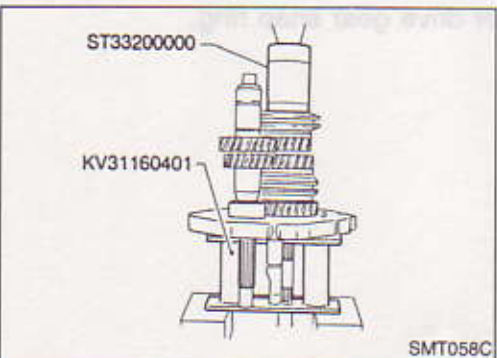

- c. Install 3rd main gear and then press 3rd & 4th synchronizer assembly.
- **Pay attention to direction of 3rd & 4th synchronizer.**

ASSEMBLY

Gear Components (Cont'd)

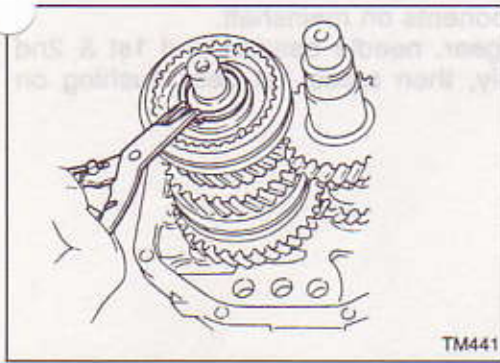

- d. Install thrust washer on mainshaft and secure it with mainshaft front snap ring. Select proper snap ring to minimize clearance of groove in mainshaft.

Allowable clearance of groove:

0 - 0.18 mm (0 - 0.0071 in)

Mainshaft front snap ring:

Refer to S.D.S.

- e. Apply gear oil to mainshaft pilot bearing and install it on mainshaft.

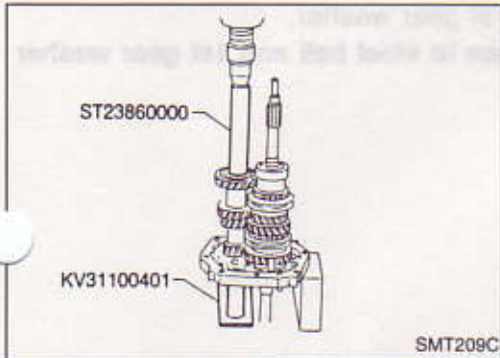

- f. Press counter drive gear with main drive gear with Tool.

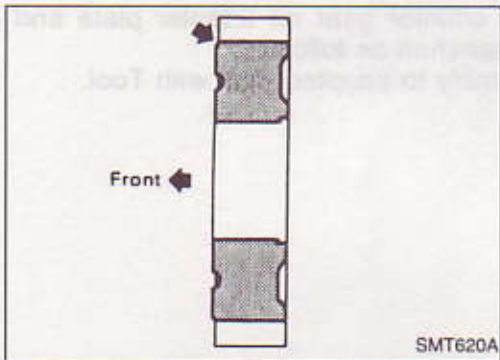

- Pay attention to direction of counter drive gear.

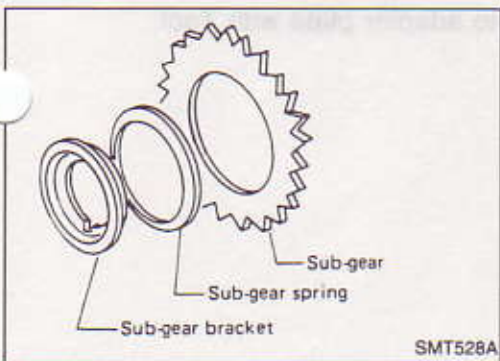

- g. Install sub-gear components.

- (1) Install sub-gear and sub-gear bracket on counter drive gear and then select proper snap ring to minimize clearance of groove in counter gear.

Allowable clearance of groove:

0 - 0.18 mm (0 - 0.0071 in)

Counter drive gear snap ring:

Refer to S.D.S.

- (2) Remove snap ring, sub-gear bracket and sub-gear from counter gear.
- (3) Reinstall sub-gear, sub-gear spring and sub-gear bracket.

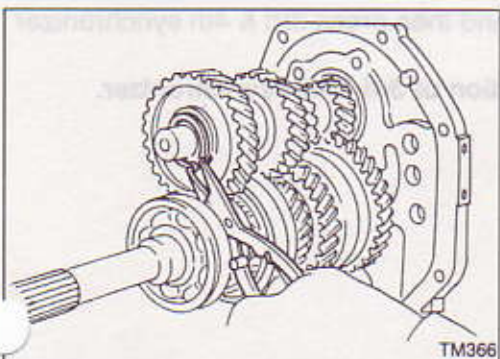

- h. Install selected counter drive gear snap ring.

ASSEMBLY

Gear Components (Cont'd)

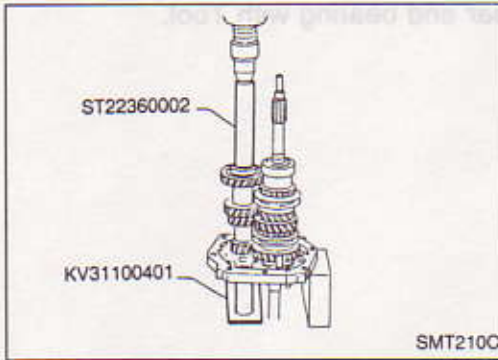

- i. Press counter gear front bearing onto counter gear.

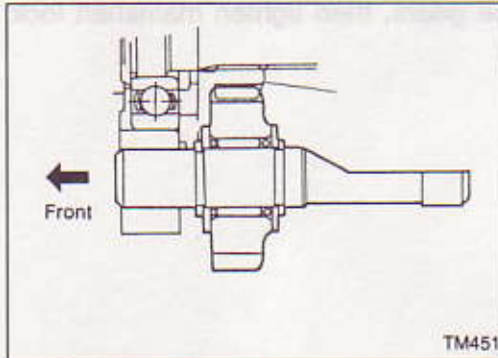

7. Install rear side components on mainshaft and counter gear as follows:

- a. Install reverse idler gear to reverse idler shaft with spacers, snap rings and needle bearing.

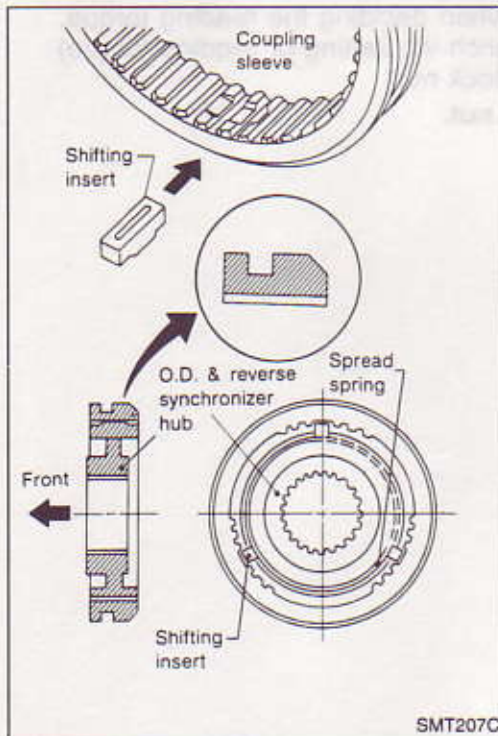

- b. Install bush, reverse main gear, needle bearing, baulk ring (reverse) and O.D. & reverse synchronizer hub to mainshaft.

- Pay attention to direction of hub.

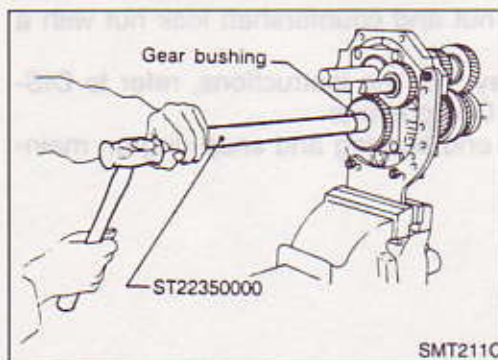

- c. Install O.D. gear bushing with Tool.
- d. Install baulk ring (O.D.), main gear and needle bearing.
- e. Install spacer, reverse counter gear and O.D. counter gear.
- O.D. main gear and O.D. counter gear should be handled as a matched set.
- f. Install thrust washer and speedometer drive gear to mainshaft.
- g. Tighten mainshaft lock nut temporarily.
- Always use new lock nut.

ASSEMBLY

Gear Components (Cont'd)

h. Install countershaft rear end bearing with Tool.

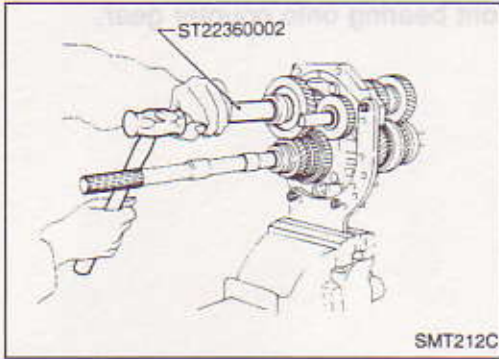

8. Mesh 2nd and reverse gears, then tighten mainshaft lock nut with Tool.

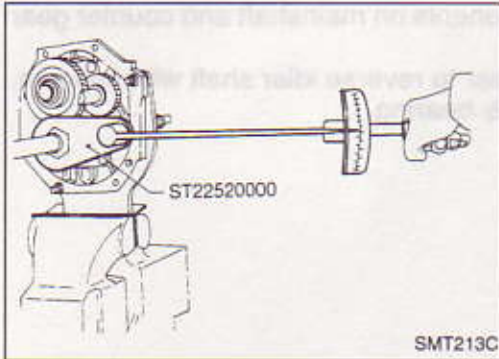

- Use the chart at left when deciding the reading torque. (Length of torque wrench vs. setting or reading torque)
9. Tighten countershaft lock nut.
- **Always use new lock nut.**

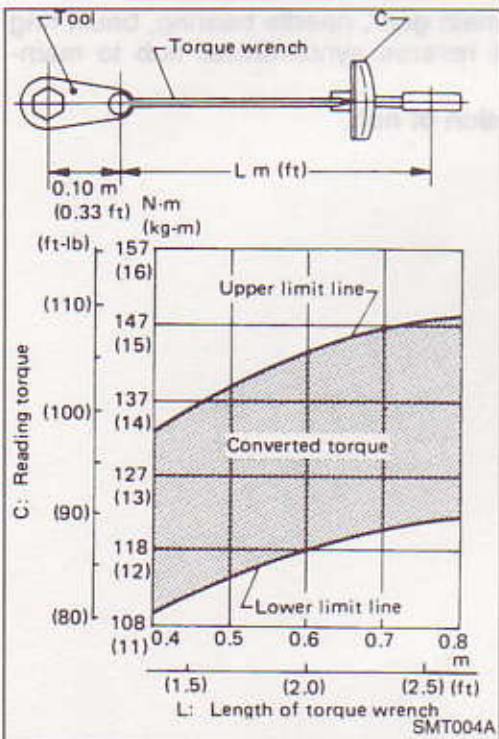

10. Stake mainshaft lock nut and countershaft lock nut with a punch.
11. Measure gear end play. For the instructions, refer to DIS-ASSEMBLY for Gear Components.
12. Install snap ring, rear end bearing and snap ring on mainshaft.

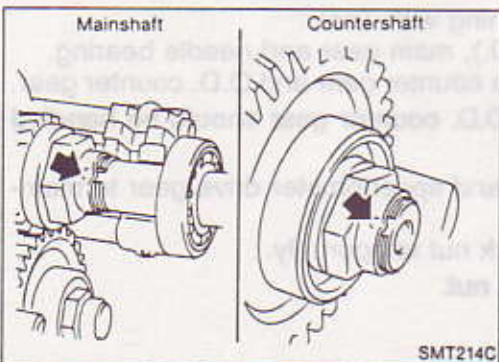

ASSEMBLY

Shift Control Components

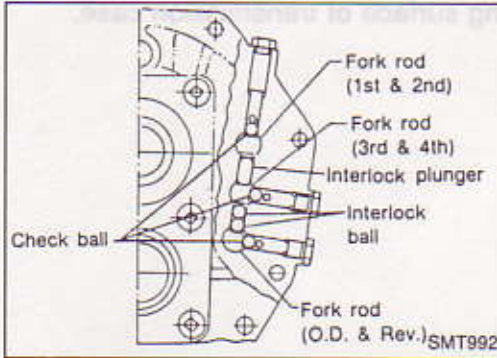

1. Install shift rods, interlock plunger, interlock balls and check balls.

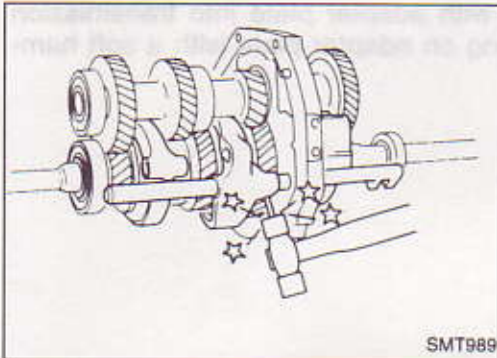

- a. 1st-2nd shift fork

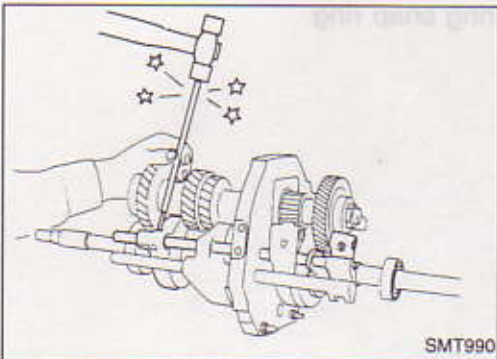

- b. 3rd-4th shift fork

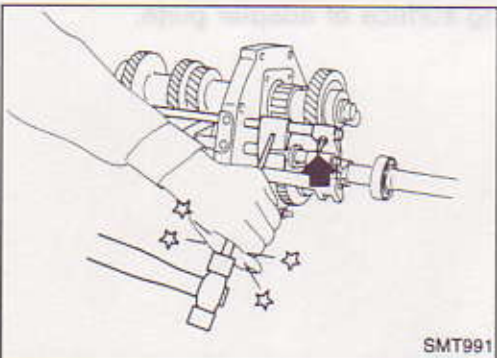

- c. O.D.-reverse shift fork.

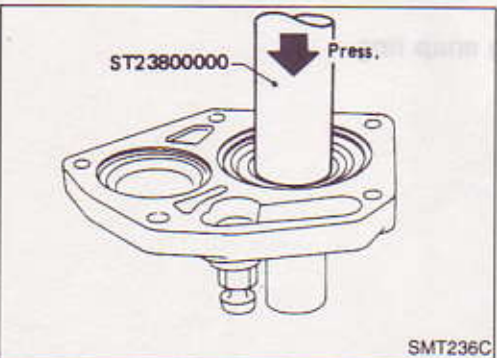

Case Components

1. Install front cover oil seal.
 - Apply multi-purpose grease to seal lip.

ASSEMBLY

Case Components (Cont'd)

2. Apply sealant to mating surface of transmission case.

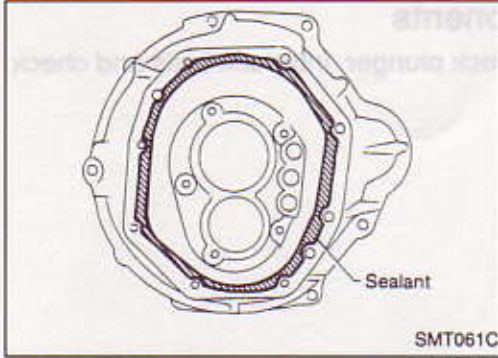

3. Slide gear assembly with adapter plate into transmission case by slightly tapping on adapter plate with a soft hammer.

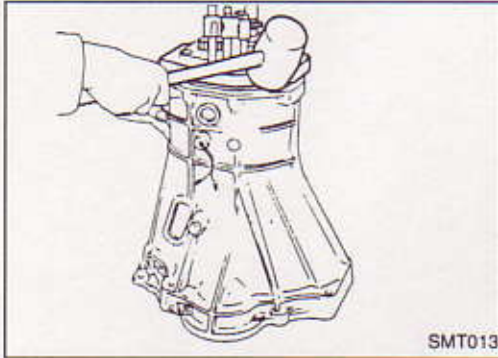

4. Install main drive bearing snap ring.

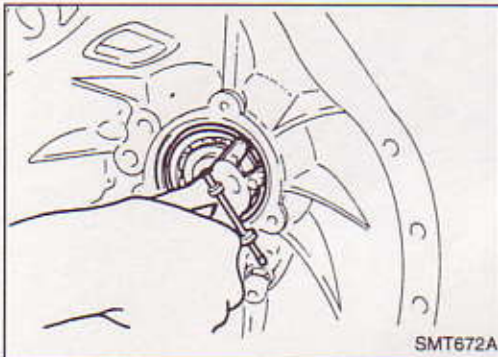

5. Apply sealant to mating surface of adapter plate.

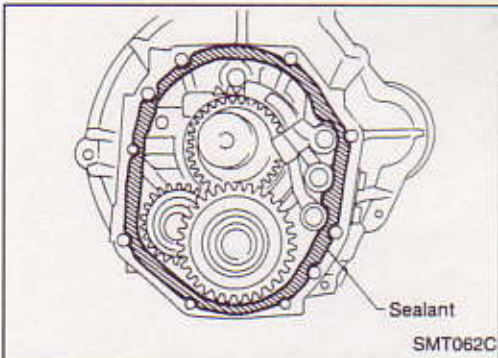

6. Install rear extension.
7. Fit main drive bearing snap ring.

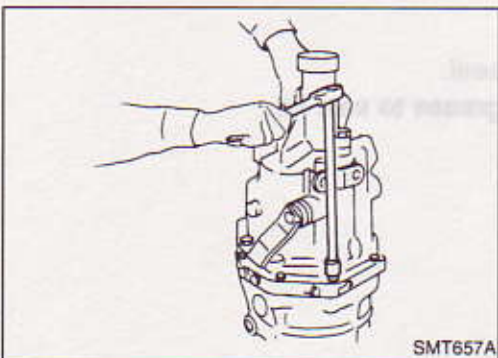

ASSEMBLY

Case Components (Cont'd)

8. Select counter front bearing shim.

Unit: mm (in)

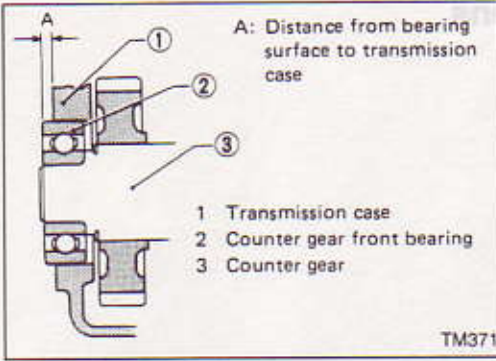

"A"	Thickness of shim	Part number
4.52 - 4.71 (0.1780 - 0.1854)	Not necessary	
4.42 - 4.51 (0.1740 - 0.1776)	0.1 (0.004)	32218-V5000
4.32 - 4.41 (0.1701 - 0.1736)	0.2 (0.008)	32218-V5001
4.22 - 4.31 (0.1661 - 0.1697)	0.3 (0.012)	32218-V5002
4.12 - 4.21 (0.1622 - 0.1657)	0.4 (0.016)	32218-V5003
4.02 - 4.11 (0.1583 - 0.1618)	0.5 (0.020)	32218-V5004
3.92 - 4.01 (0.1543 - 0.1579)	0.6 (0.024)	32218-V5005

9. Install gasket and front cover.

SERVICE DATA AND SPECIFICATIONS (S.D.S.)

General Specifications

Transmission model		RS5W71C			
Engine		SR20DE	GA16DE, LD20-II (SGX-grade)	LD20-II (except SGX-grade)	
Number of speeds		5			
Shift pattern					
Synchronmesh type		Warner			
Gear ratio	1st	3.592	3.985	4.220	
	2nd	2.057	2.246	2.455	
	3rd	1.361	1.415	1.467	
	4th	1.000	1.000	1.000	
	O.D.	0.821	0.821	0.821	
	Reverse	3.657	3.657	3.657	
Number of teeth	Mainshaft	Drive	21	21	21
		1st	33	34	36
		2nd	27	28	29
		3rd	25	26	26
		O.D.	21	21	21
		Reverse	36	36	36
	Counter-shaft	Drive	32	32	32
		1st	14	13	13
		2nd	20	19	18
		3rd	28	28	27
		O.D.	39	39	39
		Reverse	15	15	15
	Reverse idler gear		21	21	21
	Oil capacity	ℓ (Imp pt)	2.1 (3-3/4)		
	Remarks	Sub-gear	○		
		Reverse synchronizer	○		
Double baulk ring type synchronizer		2nd synchronizer			

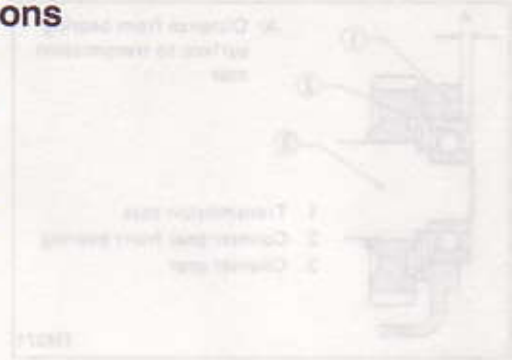

SERVICE DATA AND SPECIFICATIONS (S.D.S.)

Inspection and Adjustment

GEAR END PLAY

Gear	End play mm (in)
1st gear	0.31 - 0.41 (0.0122 - 0.0161)
2nd gear	0.11 - 0.21 (0.0043 - 0.0083)
3rd gear	0.11 - 0.21 (0.0043 - 0.0083)
O.D. gear	0.24 - 0.41 (0.0094 - 0.0161)

CLEARANCE BETWEEN BAULK RING AND GEAR

1st, 3rd, main drive and O.D. baulk ring

Unit: mm (in)

	Standard	Wear limit
1st	1.2 - 1.6 (0.047 - 0.063)	0.8 (0.031)
3rd and main drive	1.2 - 1.6 (0.047 - 0.063)	
O.D.	1.2 - 1.6 (0.047 - 0.063)	
Reverse	1.1 - 1.55 (0.0433 - 0.0610)	0.7 (0.028)

2nd baulk ring

Unit: mm (in)

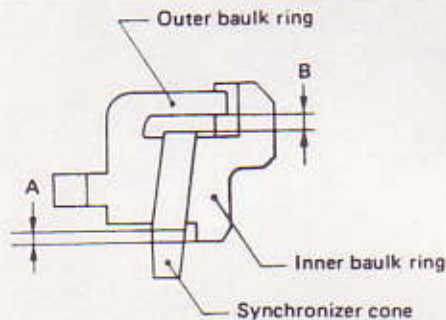

SMT044B

Dimension	Standard	Wear limit
A	0.65 - 1.1 (0.0256 - 0.0433)	0.2 (0.008)
B	0.7 - 0.9 (0.028 - 0.035)	

AVAILABLE SNAP RING

Main drive gear bearing

Allowable clearance	0 - 0.13 mm (0 - 0.0051 in)	
Thickness mm (in)	Part number	
1.73 (0.0681)	32204-78005	
1.80 (0.0709)	32204-78000	
1.87 (0.0736)	32204-78001	
1.94 (0.0764)	32204-78002	
2.01 (0.0791)	32204-78003	
2.08 (0.0819)	32204-78004	

Mainshaft 3rd & 4th synchronizer hub

Allowable clearance	0 - 0.18 mm (0 - 0.0071 in)	
Thickness mm (in)	Part number	
2.4 (0.094)	32263-V5200	
2.5 (0.098)	32263-V5201	
2.6 (0.102)	32263-V5202	

Mainshaft rear end bearing

Allowable clearance	0 - 0.14 mm (0 - 0.0055 in)	
Thickness mm (in)	Part number	
1.1 (0.043)	32228-20100	
1.2 (0.047)	32228-20101	
1.3 (0.051)	32228-20102	
1.4 (0.055)	32228-20103	

Counter drive gear

Allowable clearance	0 - 0.18 mm (0 - 0.0071 in)	
Thickness mm (in)	Part number	
1.4 (0.055)	32215-E9000	
1.5 (0.059)	32215-E9001	
1.6 (0.063)	32215-E9002	

SERVICE DATA AND SPECIFICATIONS (S.D.S.)

Inspection and Adjustment (Cont'd)

AVAILABLE SHIMS

Counter front bearing

Unit: mm (in)

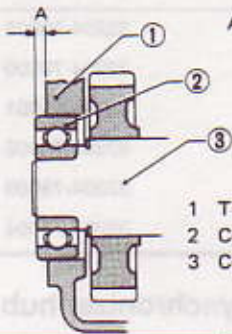

A: Distance from bearing surface to transmission case

- 1 Transmission case
- 2 Counter gear front bearing
- 3 Counter gear

SMT371

"A"	Thickness of shim	Part number
4.52 - 4.71 (0.1780 - 0.1854)	Not necessary	
4.42 - 4.51 (0.1740 - 0.1776)	0.1 (0.004)	32218-V5000
4.32 - 4.41 (0.1701 - 0.1736)	0.2 (0.008)	32218-V5001
4.22 - 4.31 (0.1661 - 0.1697)	0.3 (0.012)	32218-V5002
4.12 - 4.21 (0.1622 - 0.1657)	0.4 (0.016)	32218-V5003
4.02 - 4.11 (0.1583 - 0.1618)	0.5 (0.020)	32218-V5004
3.92 - 4.01 (0.1543 - 0.1579)	0.6 (0.024)	32218-V5005

mm (in)	mm (in)
10.00 - 10.10 (0.394 - 0.398)	10.00
10.10 - 10.20 (0.398 - 0.402)	10.10
10.20 - 10.30 (0.402 - 0.406)	10.20
10.30 - 10.40 (0.406 - 0.410)	10.30

CLEARANCE BETWEEN BULK RING AND GEAR

mm (in)	mm (in)	mm (in)
0.10 - 0.15 (0.004 - 0.006)	0.10 - 0.15 (0.004 - 0.006)	0.10
0.15 - 0.20 (0.006 - 0.008)	0.15 - 0.20 (0.006 - 0.008)	0.15
0.20 - 0.25 (0.008 - 0.010)	0.20 - 0.25 (0.008 - 0.010)	0.20
0.25 - 0.30 (0.010 - 0.012)	0.25 - 0.30 (0.010 - 0.012)	0.25

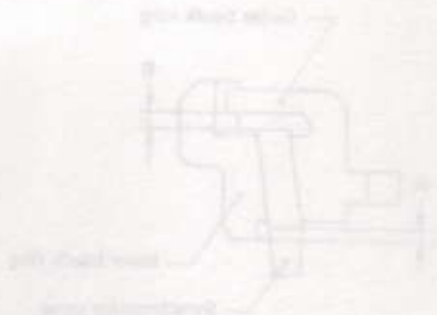

mm (in)	mm (in)	mm (in)
0.10 - 0.15 (0.004 - 0.006)	0.10 - 0.15 (0.004 - 0.006)	0.10
0.15 - 0.20 (0.006 - 0.008)	0.15 - 0.20 (0.006 - 0.008)	0.15